

AC/DC CONVERTER – 10W REGULATED

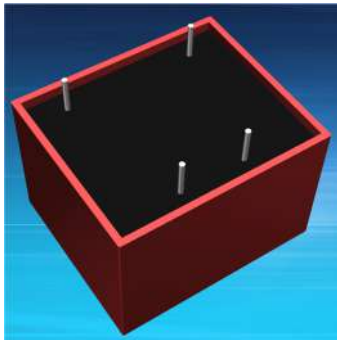

Power Supplies

10W SERIES

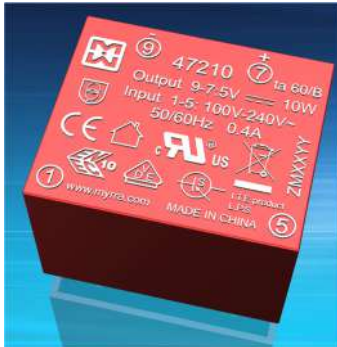

MAIN FEATURES:

- 10W Small Compact Size - PCB Mount
- Operating Altitude Up To 5000 meter
- Output Range : 3.3VDC - 24VDC
- Input Range : 85VAC - 265VAC/47 - 63Hz Or 120VDC - 370VDC
- Very Low Standby Power Consumption < 0.1W
- Better Energetic Efficiency : Meets the requirements of Energy Star and EC Code Of Conduct
- Encapsulated Design with the same footprint as an EI48 Transformer: Upgrade Your Application without redesigning the PCB
- Safety : Meer All Requirements Of IEC/EN61558-2-16, IEC/EN60950-1, IEC/EN60335-1, IEC/EN62368-1, UL60950-1, CAN/CSA C22.2 No. 60950-1-07, CE, VDE, ENEC Mark
- Materials : Uses UL 94-V0 Plastic And Resin
- EMC : Conducted and Radiated Emissions conform to EN55032, EN55014 And FCC Part 15, CLASS B, IEC/N61000-3-2 CLASS A, EN61000-3-3
- Immunity conforms to EN61000-4-2, IEC/EN61000-4-3, EN61000-4-4 EN61000-4-5, EN61000-4-6, EN610004-11



DATA SHEET

Part No	Power Rating Watts	Output Voltage (VDC)	Output Current (mA)	Ambient Temp. (°C)	Efficiency Typical	Input Range
47216	10	3.3	3000	50	>68%@230VAC	85VAC-265VAC (120VDC-370VDC)
47210	10	5.0	2000	60	>73%@230VAC	
47211	10	9.0	1100	60	>79%@230VAC	
47212	10	12	830	60	>80%@230VAC	
47213	10	15	670	60	>81%@230VAC	
47214	10	18	560	60	>81%@230VAC	
47215	10	24	420	60	>81%@230VAC	

Note: Other output voltages are available upon request.

Please refer to MYRRA's website and catalogue for MYRRA SMPS application notes.

www.myrra.com

www.myrra-powersupplies.com

contact us : contact@myrra.com

The information contained in this document is subject to change without notice.

AC/DC CONVERTER – 10W REGULATED



Power Supplies

10W SERIES

Model: 10 Watt		Specifications
AC Input Characteristics	Rated AC input Voltage	100~240Vac or 140VDC-340VDC
	AC Input Voltage Range	85~265Vac or 120VDC-370VDC
	AC Input Frequency Range	47Hz~63Hz
	Rated AC Input Frequency	50/60Hz
	Input Current	0.4A Max@85Vac~265Vac, at full load
	Standby Power	0.1W Max(Meets Requirements Of Energy Star And EC Code Of Conduct)
DC Output Characteristics	Output Voltage Accuracy	± 2% (9V,12V,15V,18V,24V Types) ± 3% (5V Type) ± 4%(3.3V Type)
	Output Voltage Line Regulation	± 0.5%(9V,12V,15V,18V,24V Types) ± 1%(3.3V and 5V Types)
	Output Voltage Load Regulation	± 1%(9V,12V,15V,18V,24V Types) ± 3% (5V Type) ± 4%(3.3V Type)
	Ripple & Noise	Max 180mVp-p@ Rated AC input, at nominal line (The measuring will be terminated with a 47uF AL E-Cap and a 0.1uF Ceramic-Cap. An oscilloscope set at 20MHz bandwidth)
	Dynamic Response	The output voltage shall not exceed ±10% rated output voltage @ 50%←→100% Load change, 1A/uS , 1KHz 50% duty cycle
	Hold Up Time	5mS min@ 100Vac ~240Vac, DC output with full load
	Turn On Delay	3S max @ 85Vac~265Vac input and DC output with full load
	Rise Time	50ms max @ 85Vac~265Vac input and DC output with full load
	Overshoot	The output voltage shall not exceed +10% rated output voltage @ Power on and 85Vac~265Vac input, and DC with full load
	Undershoot	The output voltage shall not exceed -10% rated output voltage @ Power off and 85Vac~265Vac input and DC output with full load

Please refer to MYRRA's website and catalogue for MYRRA SMPS application notes.

www.myrra.com

The information contained in this document is subject to change without notice.

www.myrra-powersupplies.com
contact us : contact@myrra.com

AC/DC CONVERTER – 10W REGULATED



10W SERIES

Power Supplies

	Efficiency	See table (Meets Requirements Of Energy Star And EC Code Of Conduct)
Protection Characteristics	Over Current Protection	The power supply shall automatically protect against over current. The power supply shall auto-recover normal operation after the fault condition is removed. No excessive heat, odour, or plastic deformation shall occur with no safety hazard during the fault
	Output Short Circuit Protection	The power supply shall withstand a continuous output short without damage in 24 hours; The short may be applied before power on, or after power on; The power supply shall resume normal operation after the short is removed, no excessive heat, odour, or plastic deformation shall occur with no safety hazard
Environmental	Operation Temperature	-20°C ~+ (see table)
	Operation Humidity	10~ 90% RH(No Condensing) @ full load
	Storage Temperature	-10°C to +35°C
	Storage Humidity	< 75%RH
	Cooling Method	Ordinary or thermostat
Safety & EMC Requirement	Dielectric Strength	Primary to Secondary: 4000Vac 5mA, 3 secs.
	Radiation	Meets EN55032,EN55014,FCC part 15, Class B. under 3dB margin
	Conduction	Meets EN55032,EN55014, FCC part 15,Class B. under 3dB margin
	Harmonic Current Disturbance	Meets IEC/EN61000-3-2:2019, Class A
	Voltage Fluctuation And Flicker	Meets EN61000-3-3:2013
	Electrostatic Discharge	Meets EN61000-4-2:2009 Contact Discharge ±4KV,Air Discharge ±8KV
	RF Field Strength Susceptibility	Meets IEC/EN61000-4-3:2019
	Electrical Fast Transient	Meets EN61000-4-4:2012, ±4KV

Please refer to MYRRA's website and catalogue for MYRRA SMPS application notes.

www.myrra.com

The information contained in this document is subject to change without notice.

www.myrra-powersupplies.com

contact us : contact@myrra.com

AC/DC CONVERTER – 10W REGULATED



Power Supplies

10W SERIES

Safety & EMC Requirement	Lightning Surge	Meets EN61000-4-5:2014,+2KV (line to line) <i>Note: surge level can be extended to 6KV with an external circuit – please refer to Myrra's website and catalogue for MYRRA SMPS application notes</i>
	Conducted Susceptibility	Meets EN61000-4-6:2014
	Voltage Dips And Interruptions	Meets EN61000-4-11:2004
	Safety Standards	Meets all requirements of : UL60950-1,CAN/CSA C22.2 No.60950-1-07, IEC/EN62368-1, IEC/EN61558-2-16, IEC/EN60335-1, CE,VDE,ENEC Mark UL certificate No.E345767 VDE certificate No.40044416
Reliability Requirement	MTBF	>200K Hours @230VAC input at max operation temperature; >550K Hours @230VAC input at 25deg.C <i>Calculated in accordance with MIL-HDBK-217-F2</i>
	Burn-In Test	The unit shall be burned in for 2~ 5hours under 230Vac input and DC with full load at an ambient temperature of 30~45 degrees C
Net Weight	Approximately 80.2 grams per product unit	
Guarantee	This product is in accordance with the European RoHS & REACH directives	

Please refer to MYRRA's website and catalogue for MYRRA SMPS application notes.

www.myrra.com

The information contained in this document is subject to change without notice.

www.myrra-powersupplies.com

contact us : contact@myrra.com

AC/DC CONVERTER – 10W REGULATED



Power Supplies

SCHEMATIC

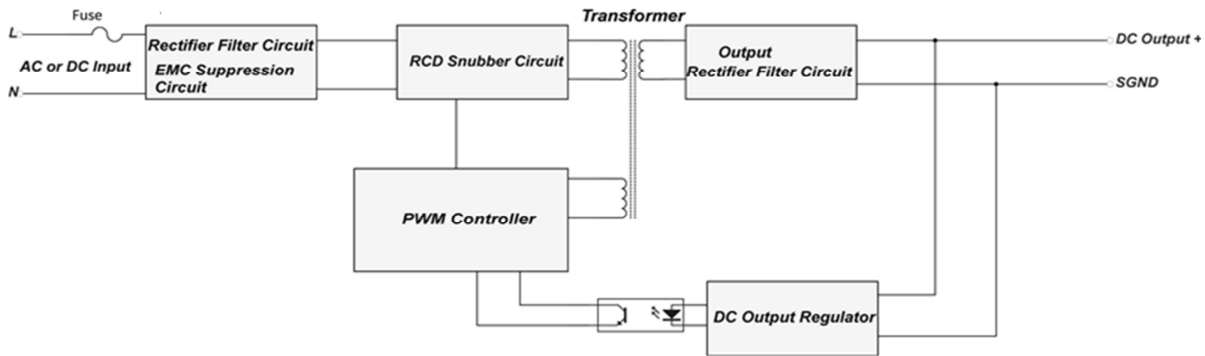

DERATING GRAPH (TYPICALLY 12V TYPE)

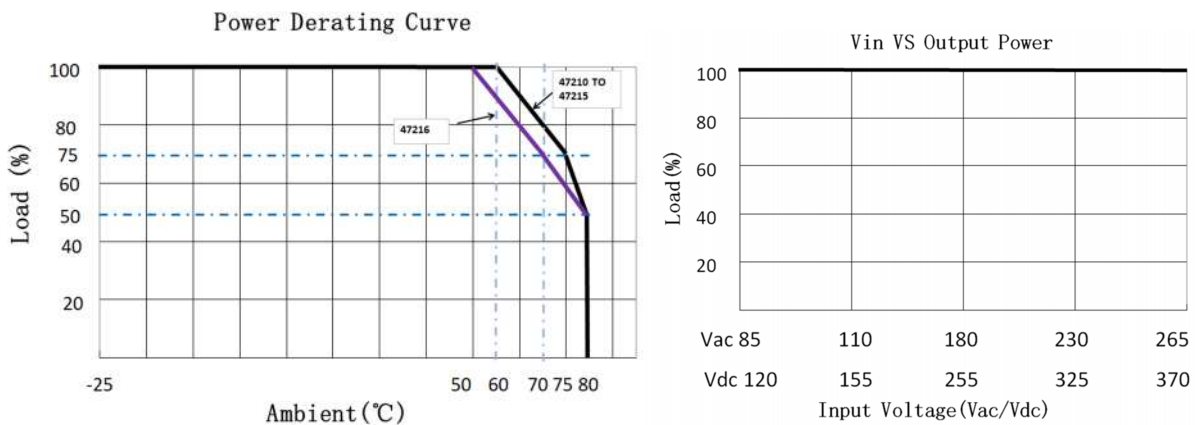

DIMENSIONS AND PINOUT 4 PINS

- PRI :
Pins 1-5: AC or DC Input
- SEC
Pin 7 : DC Output +V
Pin 9 : DC Output 0V

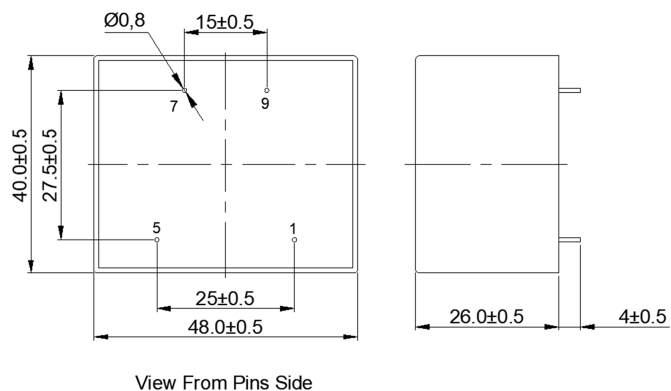

Please refer to MYRRA's website and catalogue for MYRRA SMPS application notes.

The information contained in this document is subject to change without notice.

www.myrra.com
www.myrra-powersupplies.com
 contact us : contact@myrra.com